



## -15V/-16A P-Channel Advanced Power MOSFET

### Features

- Improved dv/dt Capability, High Ruggedness.
- Maximum Junction Temperature Range (150°C)

BVDSS	-15	V
ID	-16	A
RDSON@VGS=-4.5V	10	mΩ
RDSON@VGS=-2.5V	14	mΩ

### Applications

- Battery protection
- Load switch
- Power management

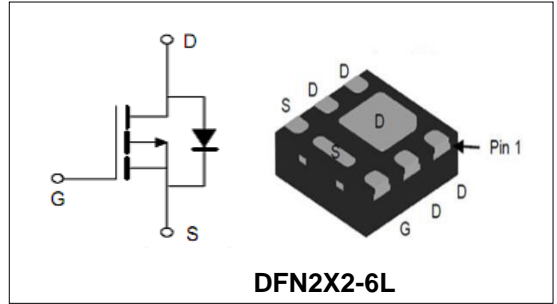

### Order Information

Product	Package	Marking	Reel Size	Reel	Carton
PTM12P16	DFN2X2-6L	SP1216 542YMW	7inch	3000PCS	120000PCS

### Absolute Maximum Ratings

Symbol	Parameter	Rating	Unit	
<b>Common Ratings (TC=25°C Unless Otherwise Noted)</b>				
$V_{(BR)DSS}$	Drain-Source Breakdown Voltage	-15	V	
$V_{GS}$	Gate-Source Voltage	±12	V	
$T_J$	Maximum Junction Temperature	150	°C	
$T_{STG}$	Storage Temperature Range	-55 to 150	°C	
$I_S$	Diode Continuous Forward Current	$T_A = 25^\circ C$	-16	A
<b>Mounted on Large Heat Sink</b>				
$I_{DM}$	Pulse Drain Current Tested (Silicon Limit) (Note1)	$T_A = 25^\circ C$	-32	A
$I_D$	Continuous Drain current	$T_A = 25^\circ C$	-16	A
$P_D$	Maximum Power Dissipation	$T_A = 25^\circ C$	2.8	W
$R_{\theta JA}$	Thermal Resistance Junction-to-Ambient (Note2)		44.6	°C/W

**-15V/-16A P-Channel Advanced Power MOSFET**

Symbol	Parameter	Condition	Min.	Typ.	Max.	Unit
<b>Static Electrical Characteristics @ T<sub>J</sub> = 25°C (unless otherwise stated)</b>						
V <sub>(BR)DSS</sub>	Drain- Source Breakdown Voltage	VGS=0V ID=-250μA	-15	--	--	V
I <sub>DSS</sub>	Zero Gate Voltage Drain current	VDS=-15V,VGS=0V	--	--	-1	μA
I <sub>GSS</sub>	Gate-Body Leakage Current	VGS=±12V,VDS=0V	--	--	±100	nA
V <sub>GS(TH)</sub>	Gate Threshold Voltage	VDS=VGS,ID=-250μA	-0.4	-0.6	-1	V
R <sub>DS(ON)</sub>	Drain-Source On-State Resistance (Note3)	VGS=-4.5V, ID=-7A	--	10	16	mΩ
		VGS=-2.5V, ID=-6A	--	14	21	mΩ
<b>Dynamic Electrical Characteristics @ T<sub>J</sub> = 25°C (unless otherwise stated) (Note4)</b>						
C <sub>iss</sub>	Input Capacitance	VDS= -6V, VGS=0V, F=1MHz	--	1840	--	pF
C <sub>oss</sub>	Output Capacitance		--	395	--	pF
C <sub>rss</sub>	Reverse Transfer Capacitance		--	366	--	pF
Q <sub>g</sub>	Total Gate Charge	VDS= -6V, ID= -6A, VGS= -4.5V	--	14	--	nC
Q <sub>gs</sub>	Gate-Source Charge		--	1.8	--	nC
Q <sub>gd</sub>	Gate-Drain Charge		--	3.9	--	nC
<b>Switching Characteristics (Note4)</b>						
t <sub>d(on)</sub>	Turn-on Delay Time	VDD=-6V, ID=-1A, RG=6Ω, RL=6Ω,	--	30	--	nS
t <sub>r</sub>	Turn-on Rise Time		--	55	--	nS
t <sub>d(off)</sub>	Turn-off Delay Time		--	87	--	nS
t <sub>f</sub>	Turn-off Fall Time		--	73	--	nS
<b>Source- Drain Diode Characteristics @ T<sub>J</sub> = 25°C (unless otherwise stated)</b>						
V <sub>SD</sub>	Forward on voltage (Note3)	IS=-7A,VGS=0V	--	--	-1.2	V

Note:

1. Repetitive Rating: Pulse width limited by maximum junction temperature.
2. Surface Mounted on FR4 Board, t ≤ 10 sec
3. Pulse Test: pulse width ≤ 300 us, duty cycle ≤ 2%.
4. Guaranteed by design, not subject to production testing.



-15V/-16A P-Channel Advanced Power MOSFET

Typical Characteristics

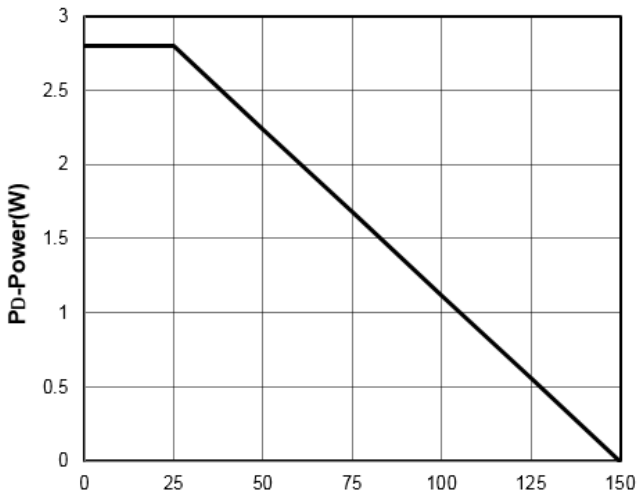

Figure1:  $T_J$  -Junction Temperature ( $^{\circ}C$ )

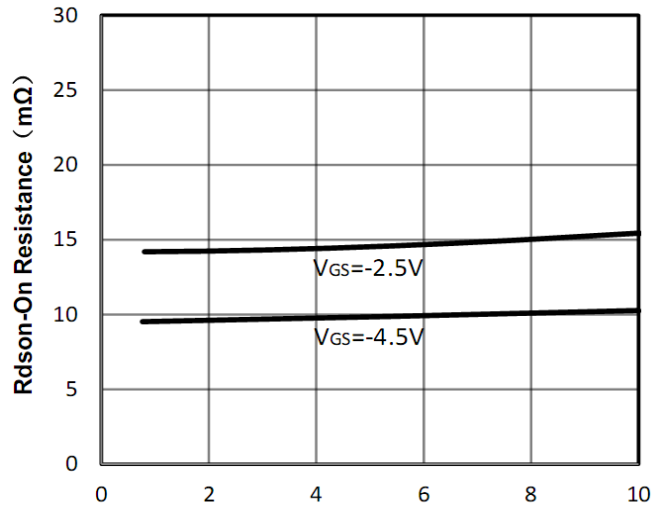

Figure2:  $I_D$  -Drain Current (A)

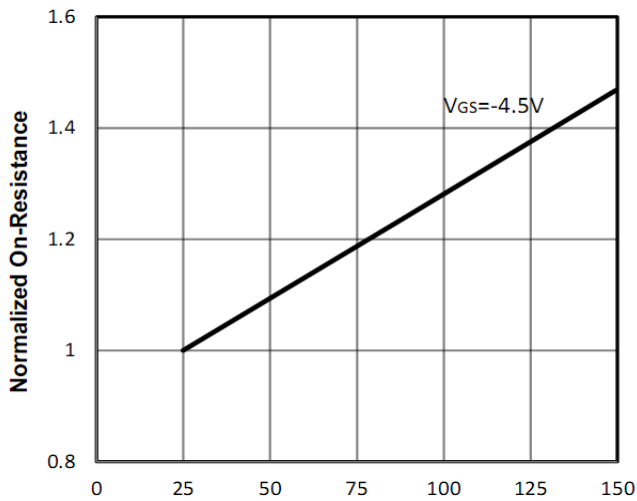

Figure3:  $T_J$  Junction Temperature ( $^{\circ}C$ )

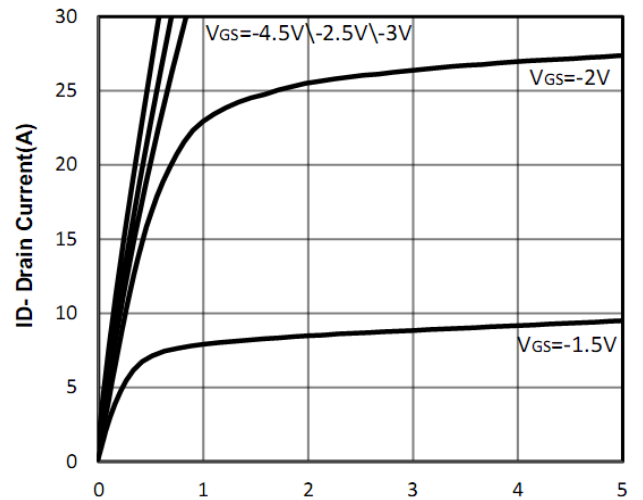

Figure4:  $V_{DS}$  -Drain Source Voltage (V)

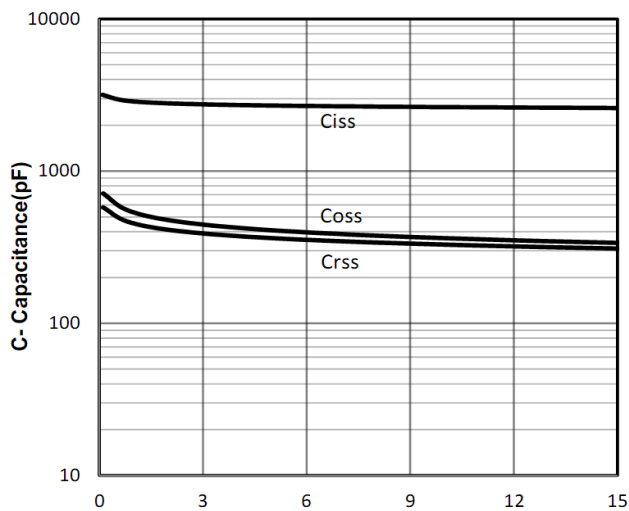

Figure5:  $V_{DS}$  -Drain Source Voltage (V)

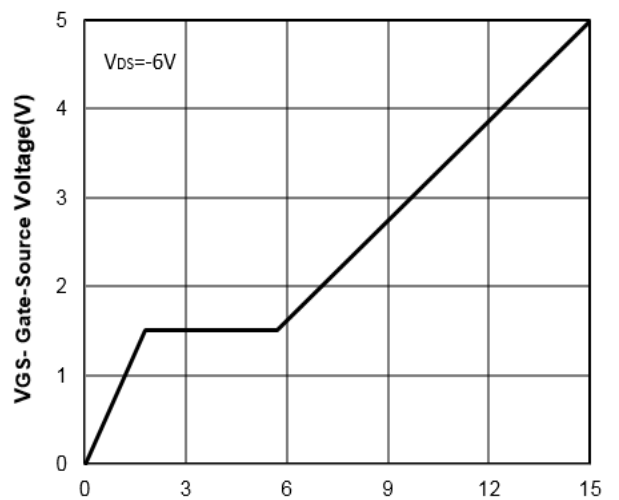

Figure6:  $Q_g$  -Gate Charge (nC)



-15V/-16A P-Channel Advanced Power MOSFET

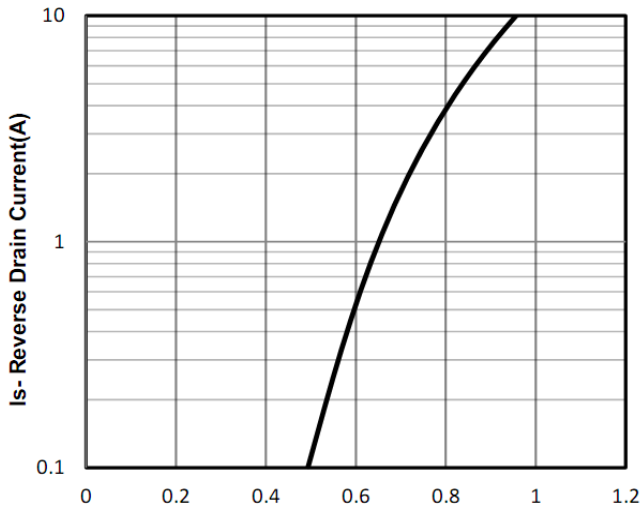

Figure7: -Vsd -Source Drain Voltage (V)

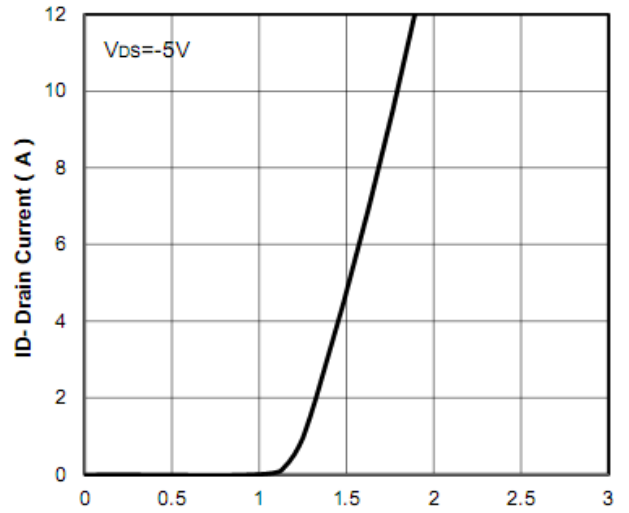

Figure8: -Vgs -Gate Source Voltage (V)

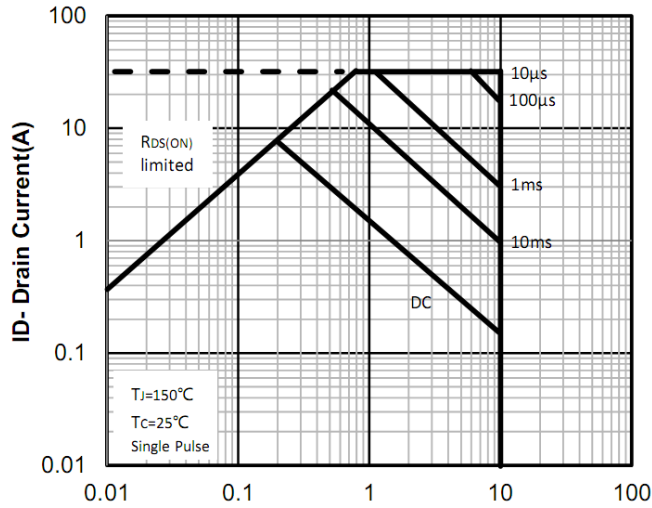

Figure9: -Vds- Drain Source Voltage (V)

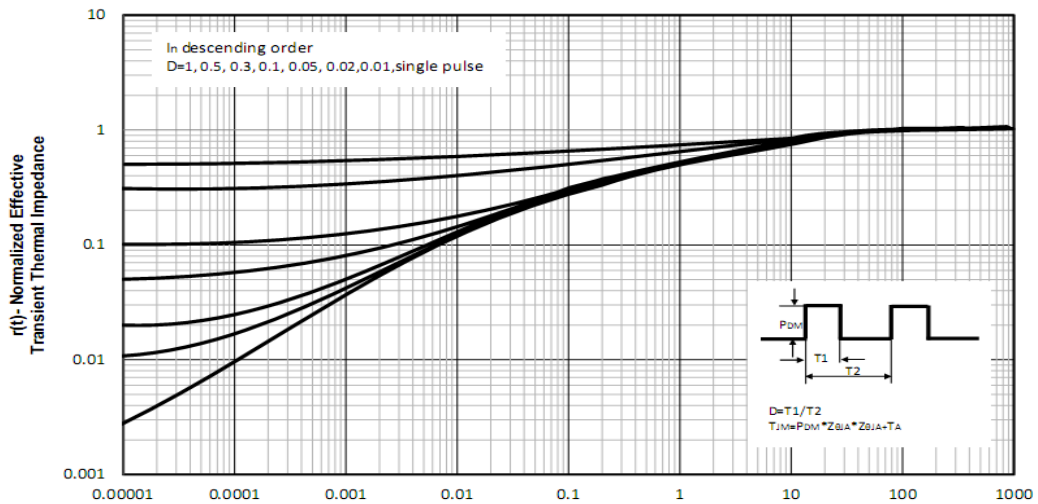

Figure10: Square Wave Pulse Duration (sec)

## -15V/-16A P-Channel Advanced Power MOSFET

### Test Circuit and Waveform:

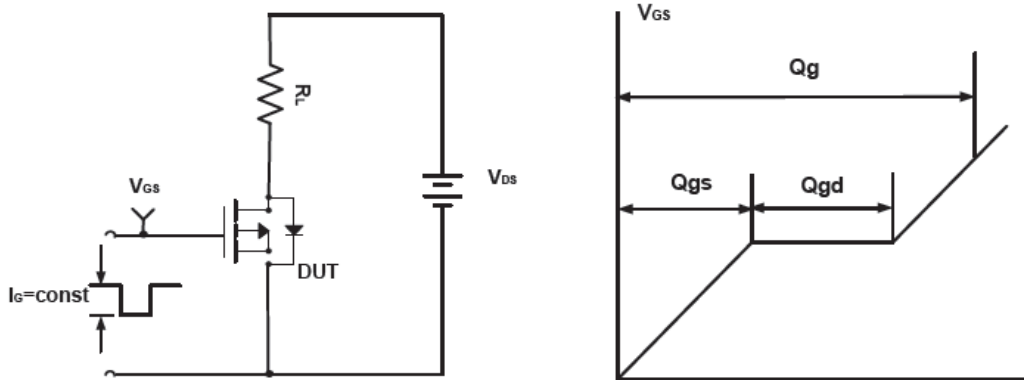

Figure A Gate Charge Test Circuit & Waveforms

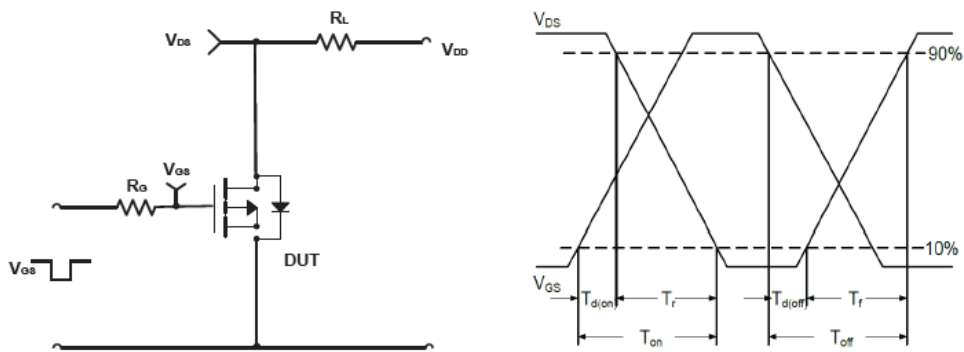

Figure B Switching Test Circuit & Waveforms

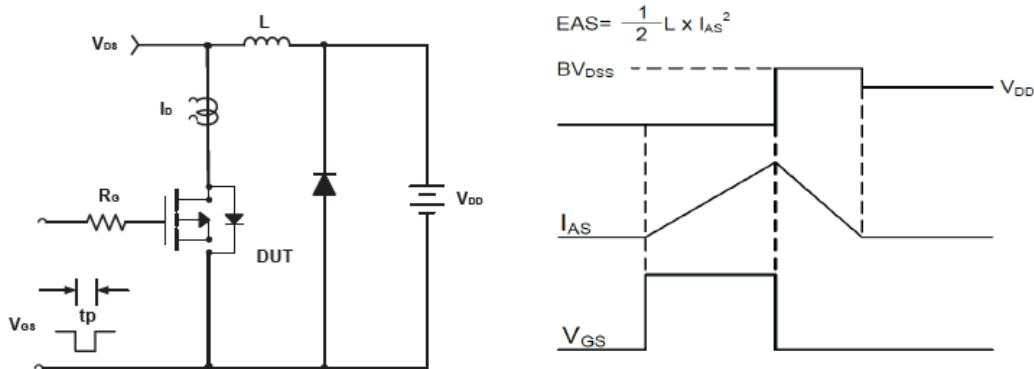
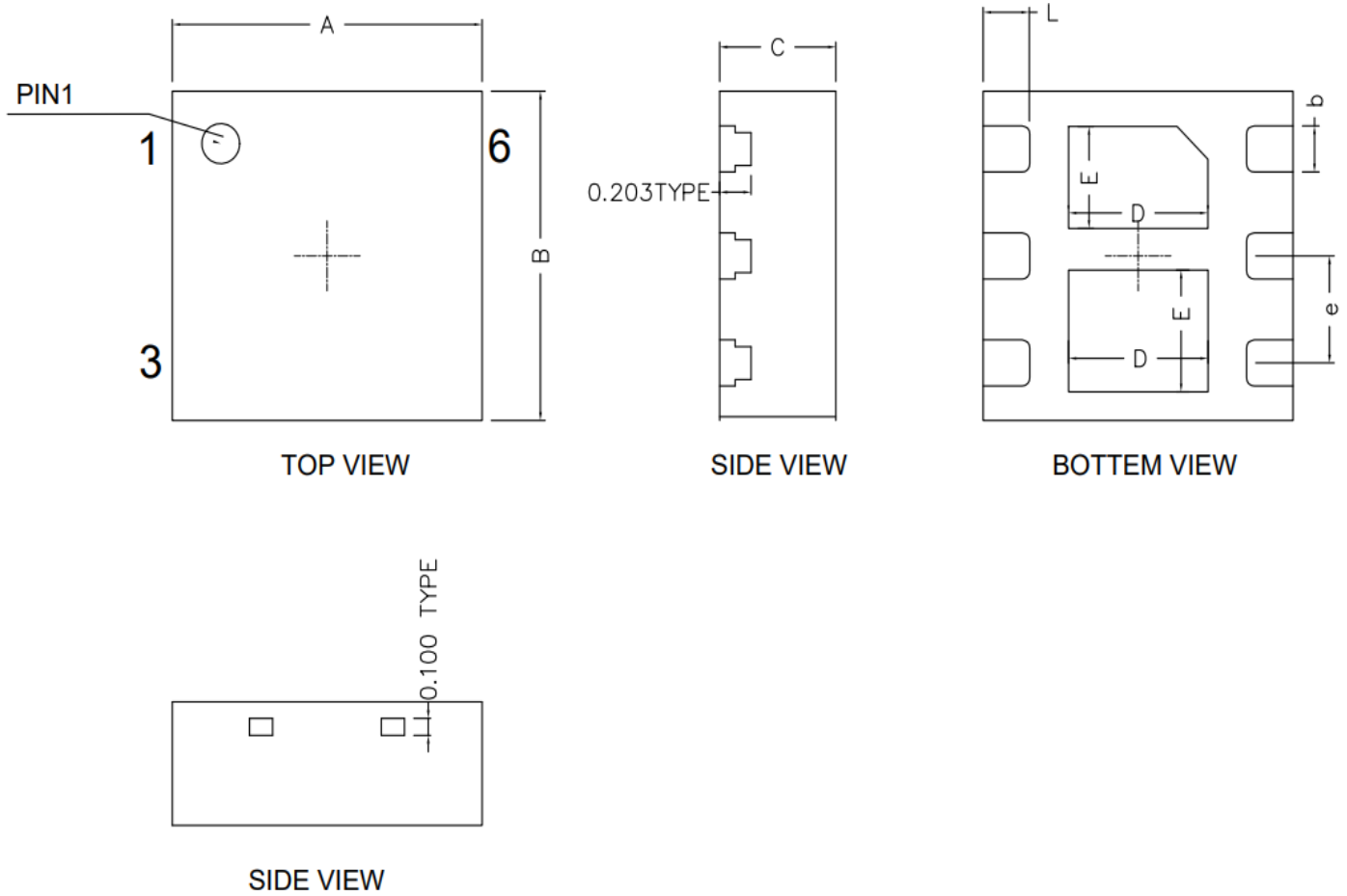

Figure C Unclamped Inductive Switching Circuit & Waveforms



-15V/-16A P-Channel Advanced Power MOSFET

DFN2X2-6L Package Outline Dimensions (Units: mm)



COMMON DIMENSIONS  
(UNITS OF MEASURE IS mm)

	MIN	NORMAL	MAX
A	1.900	2.000	2.100
B	1.900	2.000	2.100
C	0.700	0.750	0.800
D	0.850	0.900	0.950
E	0.690	0.740	0.790
L	0.250	0.300	0.350
b	0.230	0.280	0.330
e		0.650	TYPE